

## Z1186-ST and Z1188-ST SERIES Zurn Engineered Oil Interceptors with Integral Storage Tank

### OPERATION

**Figure 1** below shows the conditions inside the interceptor in a “non-operating” mode. It can be seen that the oil has separated itself from the water. The oil is floating on the surface of the water in the main separation compartment and the top of the oil is below the top of the adjustable oil draw-off gate plate (see “How To Set Adjustable Draw-off” section).

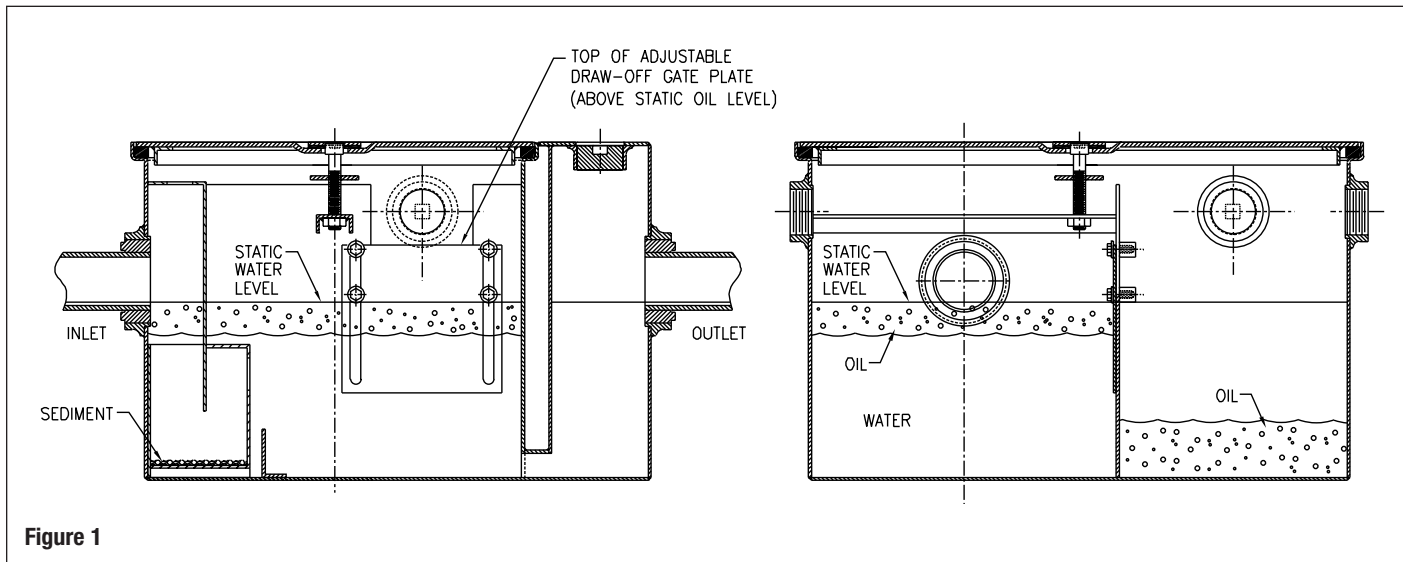

Figure 1

**Figure 2** below shows the conditions inside the interceptor in an “operating” or “flowing” mode. The oil/water mixture flows from the inlet piping into the interceptor and causes the oil/water level to rise. The mixture is directed downward into and through a removable sediment bucket. Heavier particles and sediment are collected in the bucket while the oil/water mixture continues through the bucket and is directed into the main separation compartment. The oil separates from the water by rising to the top and is now on the surface of the water. The oil/water level inside the interceptor has risen to a level which puts the layer of oil above the top of the adjustable draw-off gate plate allowing the oil to “spill” over the top of the gate plate and into the oil storage compartment. The water exits the main separation compartment through the outlet opening at the bottom of the unit passing through the outlet trap and into the discharge waste system plumbing.

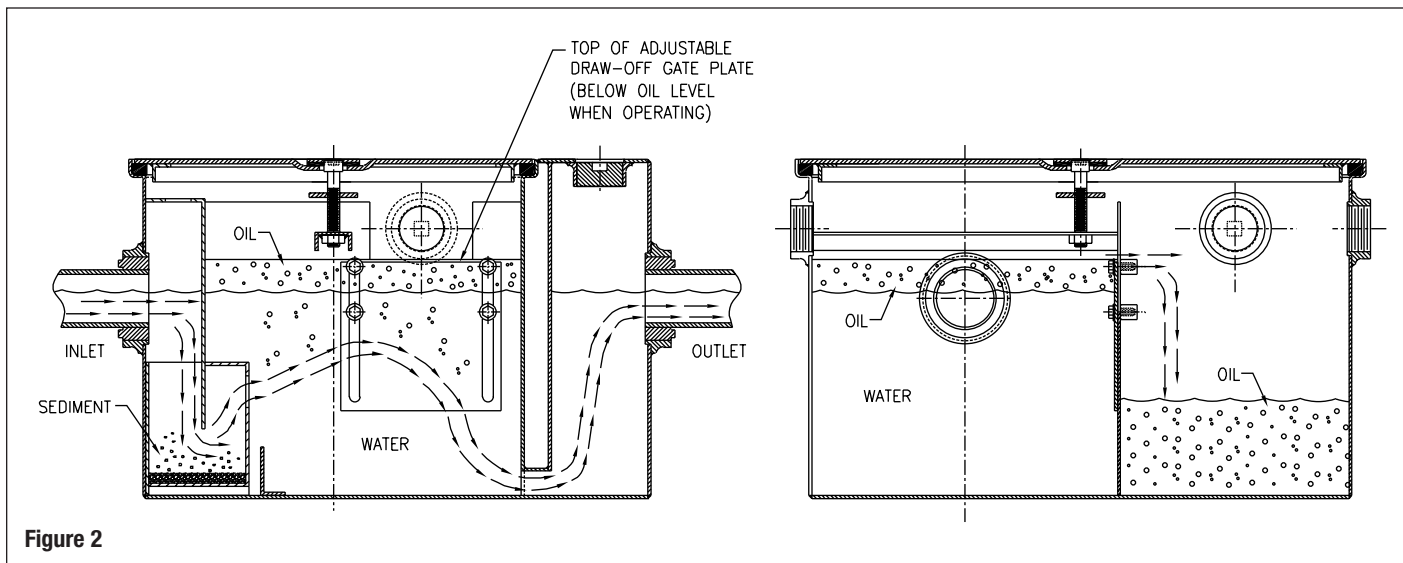

Figure 2